

TRACKER

WASH⁴ 575

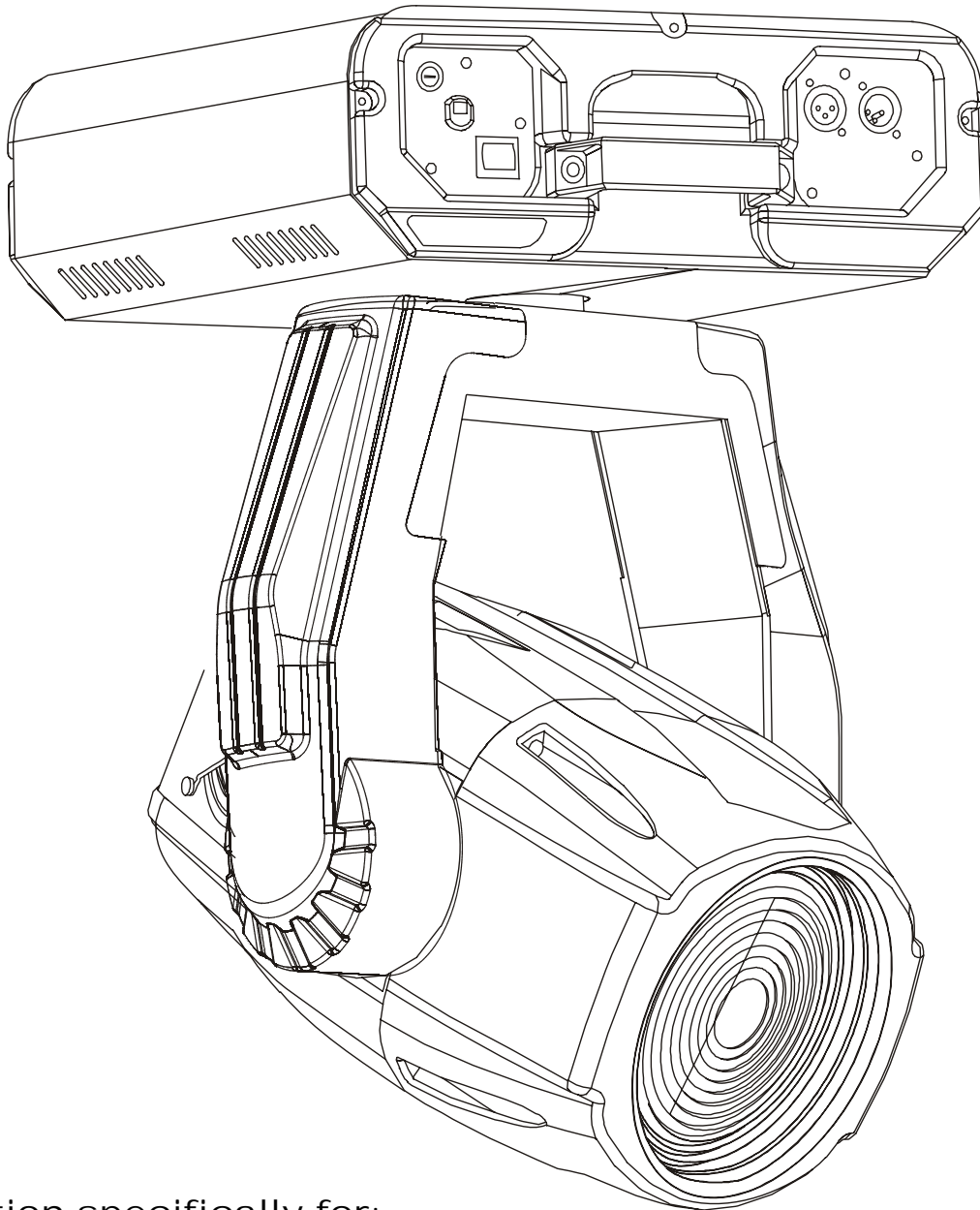

Information specifically for:
IL-TRACKER575W/1



CE
V1.2

This manual contains important information.
Please read before operating fixture.

© 2005 Techni-Lux Inc.

IMPORTANT INFORMATION

Save original packing and documentation for warranty, service and return issues.

Limited Warranty: This warranty covers defects or malfunctions in this equipment. This warranty lasts for a period of one year from date of purchase. It is the owner's responsibility to provide invoices for proof of purchase, purchase date and dealer or distributor. If purchase date can not be provided, warranty period will start at manufacture date. It is the sole discretion of Techni-Lux to repair or replace parts or equipment. All shipping will be paid by purchaser. This warranty does not cover lamps, fuses, belts, power semiconductors, relays, cleaning, standard maintenance adjustments or normal wear items or any problem resulting from the following: improper wiring, incorrect voltage (including low or over voltage conditions and lightning), abuse, misuse, improper maintenance or an act of God or damage resulting from shipping. Warranty will be null and void if the product is altered, modified, misused, damaged, or subjected to unauthorized repairs. Lamps are covered by relevant manufacturer warranty. This warranty gives you specific legal rights, and you may also have other rights which vary from state to state. Any liability for consequential and incidental damages is expressly disclaimed. No other warranty, expressed or implied is made. Techni-Lux liability in all events is limited to, and shall not exceed, the purchase price paid.

Returning equipment and Repairs: All returns must be accompanied by a Return Merchandise Authorization (RMA) number and sent pre-paid. Contact the dealer or Techni-Lux directly to obtain an RMA. The RMA number must be clearly listed on the shipping label. Due care must be exercised in packing all merchandise to be returned. All repairs must be accompanied by a written explanation of the claimed problem or error encountered. Techni-Lux is solely responsible for determining a product's eligibility for coverage under warranty. If returning for consideration of credit, all accessories and documentation, original protective material and cartons must be included and the equipment, packing and carton must be in new resalable condition. Credit for returned merchandise will be issued at the lowest current price and is subject to a restocking fee of 20%. No returns accepted on discontinued items. Techni-Lux is not responsible for merchandise damaged in transit and reserves the right to refuse any return that is damaged by the carrier, not accompanied by a Return Authorization Number (RMA#) or sent by freight collect.

Claims: All claims must be made within seven (7) days of receipt of merchandise. Any physical damage must be reported to carrier upon receipt of merchandise.

Please record the following information for future reference:

Model Number: IL-TRACKER575W/1

Serial Number: _____

Dealer: _____

Date of Purchase: _____

www.Techni-Lux.com
10779 Satellite Boulevard
Orlando, FL 32837
U.S.A.

Table of Contents

Specifications	5
<i>Fixture Overview</i>	5
<i>Physical</i>	5
<i>Lamp Source</i>	5
<i>Environmental</i>	6
<i>Electrical</i>	6
<i>Control</i>	6
<i>Optics</i>	6
<i>Gobo / Color Size</i>	6
<i>Rigging</i>	6
Unit Parts	7
Unpacking	8
Power	9
<i>Voltage Selection</i>	9
Lamp	10
<i>Lamp Installation</i>	10
<i>Lamp Alignment</i>	11
Mounting	11
Data Link DMX-512	12
<i>Data Terminator</i>	12
<i>Adapter 5-to-3 pin</i>	12
Control Panel Menu	13
Start Address	13
<i>Example</i>	13
DMX-512 Channels	14
<i>CH 1-4 : Pan / Tilt Movement</i>	14
<i>CH 5 : Movement Speed Pan/Tilt</i>	14
<i>CH 6 : Control Reset/Lamp</i>	15
<i>CH 7 : Fixed Color Wheel</i>	15
<i>CH 8 : Cyan Mix</i>	16
<i>CH 9 : Magenta Mix</i>	16
<i>CH 10 : Yellow Mix</i>	16
<i>CH 11 : CMY Mix Speed</i>	16
<i>CH 12 : Color Presets CMY</i>	17
<i>CH 13 : Effects</i>	17
<i>CH 14 : Zoom</i>	17
<i>CH 15 : Shutter</i>	18
<i>CH 16 : Dimmer</i>	18
Photometric Charts	19
DMX-512 Background	20
Maintenance	21
Troubleshooting	22
Wiring Diagram	23
Accessory Items	24

Specifications

Fixture Overview

- Pan range of movement: 530 degrees
- Tilt range of movement: 280 degrees
- High resolution 16 Bit Pan/Tilt movement for accurate positioning
- Pan/Tilt motor speed
- Consistent & auto correcting Pan/Tilt positioning
- Color wheel with 7 dichroic color filters plus open
- CYM color mixing system: Cyan, Yellow & Magenta
- CYM variable motor speed
- 18 pre-set CYM color mixed macros
- Remote lamp on and off
- Remote reset
- Motorized beam shape rotation
- Frost effect
- Motorized zoom adjustable from 7 to 28 degrees
- Variable shutter for strobe effects and quick blackouts
- Motorized dimmer from 0 to 100%
- Control via DMX512 using 3 pin In/Out XLRs
- Uses 16 Channels of DMX
- Digital display for DMX addressing and fixture settings
- Ventilation via forced air
- High quality 200mm fresnel lens
- Anti-reflective coated glass optics
- Dual heat glass filters
- High efficiency glass reflector
- Lamp: CSR575/2SE or MSR575/2
- Luminous output: 49,000 Lux

Physical

Color	Black
Width	18 in (45.7cm)
Depth	18 in (45.7cm)
Height	27 in (68.6 cm)
Weight	88 lbs (39.9 kg)
Gross Weight	102 lbs (46.3 kg)

Lamp Source

Lamp Type	575w Metal Halide Discharge
Base	GX9.5
Lamps	GE - CSR575/2SE or Phillips - MSR575/2
Lamp Specs	575w, 1000 Hour, 7200°K Color Temp, 49000 Lumens
Ballast Type	Magnetic

Environmental

Maximum ambient temperature	105°F (40°C)
Maximum exterior surface temperature	176°F (80°C)
Minimum distance to flammable surface	3.3ft (1m)
Minimum distance to illuminated surface	4ft (1.2m)

Electrical

Factory Setting	120v 60Hz
Selectable Voltages	100v / 115v / 208v / 220v @ 50 or 60Hz
Rated Power	850W, 7A @ 120v
Fuses	15A Time Delay (Slow) Size: ¼" x 1¼"

Control

Protocol	USITT DMX512 (1990)
Channels	16
Pan / Tilt Resolution	16 bit
Data I/O	3 Pin XLR (Cannon)
Modes	Master / Slave / DMX

Optics

Reflector	High efficiency Dichroic coated Parabolic
Lenses	Anti-reflective coated
Zoom	7° to 28° continuous adjustment
Fresnel	200mm

Gobo / Color Size

Color Diameter	Fixed non-interchangeable
----------------	---------------------------

Rigging

Position	Floor or Truss mount
Orientation	Any
Mounting Points	2
Clamp Orientation	0°, 90°, 180°, 270°
Safety Point	Eye Bolt

Unit Parts

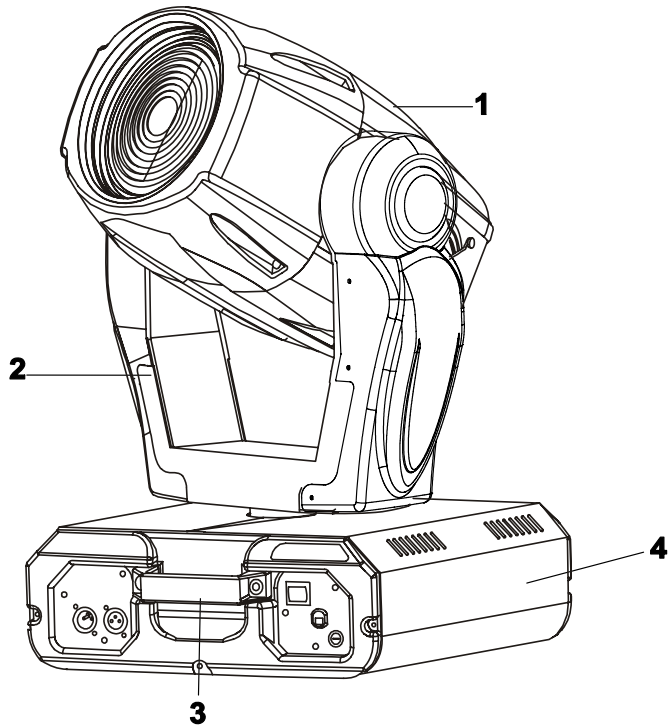

- 1 - Moving head
- 2 - Yoke
- 3 - Carry handles
- 4 - Base

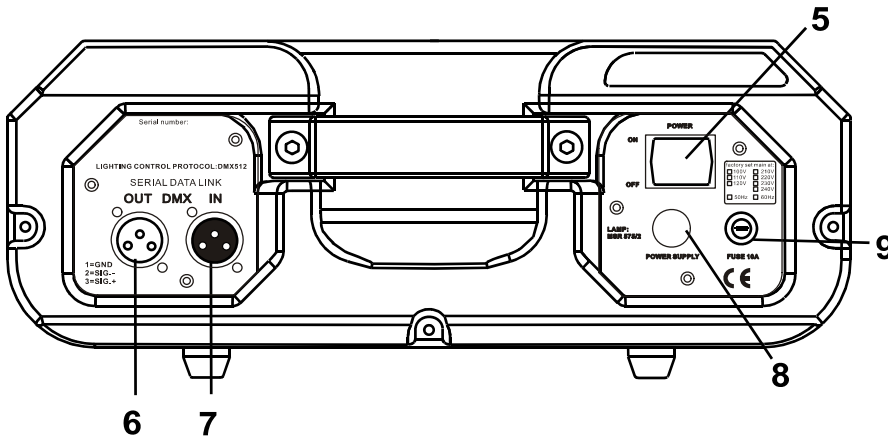

- Rear panel:
- 5 - Power switch
 - 6 - DMX output
 - 7 - DMX input
 - 8 - Power cord
 - 9 - Fuse holder

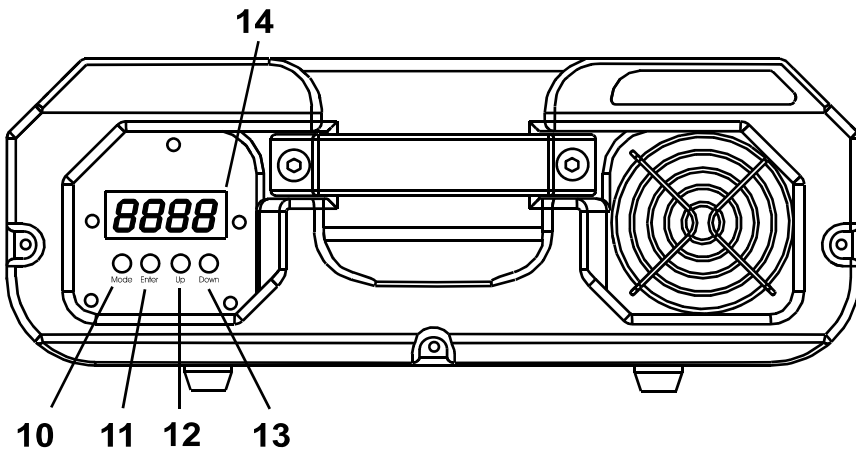

- Front panel:
- 10 - Mode-button
 - 11 - Enter-button
 - 12 - Up-button
 - 13 - Down-button
 - 14 - Display

Unpacking

Immediately upon receipt, carefully unpack and inspect the fixture to verify that all parts are present and have been received in good condition. If any parts appear damaged from shipping or the shipping carton shows signs of mishandling, retain all packing material for inspection and notify the shipper immediately. Save all original packing and carton. In the event that the merchandise is to be returned, the original carton and packing must be used. The customer will be billed for a new carton and packing if merchandise is received without the original carton and packing. The plastic bag shipped with the fixture can be used to keep the fixture clean if stored or installed in a temporarily dusty environment. Do not operate fixture with plastic bag in place.

Save Shipping Materials

The packing and carton are designed to provide the fixture with protection during shipping. Save original packing and documentation for warranty, service and return issues. Additional charges will be applied to return items not received in original or incomplete packing.

Claims

Physical damage must be reported to the Freight Carrier or Shipping Company upon receipt of merchandise. Damage incurred in shipping is the responsibility of the Freight Carrier or Shipping Company. It is the customer's obligation in the event that merchandise is received damaged caused by shipping to notify the Freight Carrier or Shipping Company immediately. All other claims not related to damage incurred during shipping must be made to the Dealer or Distributor within 7 (seven) days of receiving merchandise.

Returns

Returned merchandise must be sent prepaid, in the original packing with a Return Merchandise Authorization number (RMA) clearly listed on the shipping label. Items sent by Freight Collect or without a RMA number will be refused. Call your sales person and request a RMA prior to shipping. Be prepared to provide the model number, serial number and a brief description of the nature of the return. Shipping damage resulting from inadequate packaging is the customer's responsibility. Customer will be charged additional shipping charges to return products received in non original packing and or cartons.

Power



Do not apply power to the fixture until input voltage setting and power source are verified. For protection against electric shock, fixture must be connected to suitable earth ground. Make sure fixture is cool and disconnected from power mains before any service.

The listed current rating is its average current draw under normal conditions. All fixtures must be powered directly from a switched circuit. This fixture cannot be run on a rheostat or dimmer circuit even if used solely for a 0% to 100% switching. Before applying power to a fixture, check that the fixture's input voltage matches the power source voltage. Consult a qualified electrician if there are any concerns about proper connection to power.

Cable (EU)	Cable (US)	Pin	International
Brown	Black	Live	L
Light blue	White	Neutral	N
Yellow/Green	Green	Earth	⊕

Voltage Selection



Make sure fixture is cool and disconnected from power mains before any service.

This fixture ships from the factory set for 115v 60Hz operation unless otherwise specified or marked. Before accessing the Transformer Connection, make sure fixture is cool and physically disconnected from power mains. Remove the metal cover that extends across the base from the Power Input to the Display. It is held by 9 Phillips screws. Two connections must be moved to adjust input voltage and one must be moved to adjust Line Frequency.

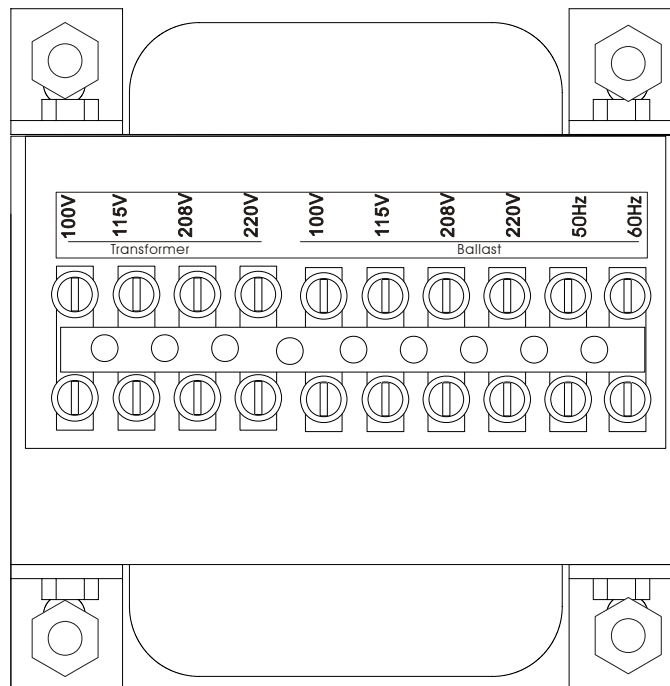

Lamp



Make sure fixture is cool and disconnected from power mains before any service.
Do not touch the lamp glass with bare fingers. Wear eye protection when handling lamp.

When operating, always allow the lamp to cool at least 5 minutes before attempting to re-strike the lamp. Not doing so can cause damage to the fixture and lamp. This fixture uses a 575w Metal Halide Discharge lamp. Either a CSR575/2SE from GE or a MSR575/2 from Phillips can be fitted. Both lamps have an average rated life of 1000 hours. The lamp manufacturer determines the rated lamp life under specific test conditions. Factors such as the number of strikes, lamp orientation, line voltage and lamp temperature all affect the actual number of hours a lamp will operate. Lamp temperature is the most controllable and with routine cleaning and maintenance, can be kept in the optimal range to allow the maximum possible life. As Discharge lamps age, the glass envelope becomes weaker increasing the chance of failure due to the high internal pressures. Rupture could result in damage to the fixture and/or injure people nearby. Lamp manufacturers state operating a lamp beyond its rated number of hours constitutes a considerable risk for lamp rupture. Lamp manufacturers recommend lamps be replaced once the rated life of a lamp has been reached.

Lamp Installation

1. Physically disconnect fixture from power mains.
2. Locate the Lamp Cover. Do not proceed until the Lamp Cover is cool to touch.
3. Remove the 3 fastening screws labeled X, Y and Z.
4. Carefully draw out Lamp Cover and lamp. Remove old lamp (if installed). Never handle lamps with bare hands. Dispose of lamp properly.

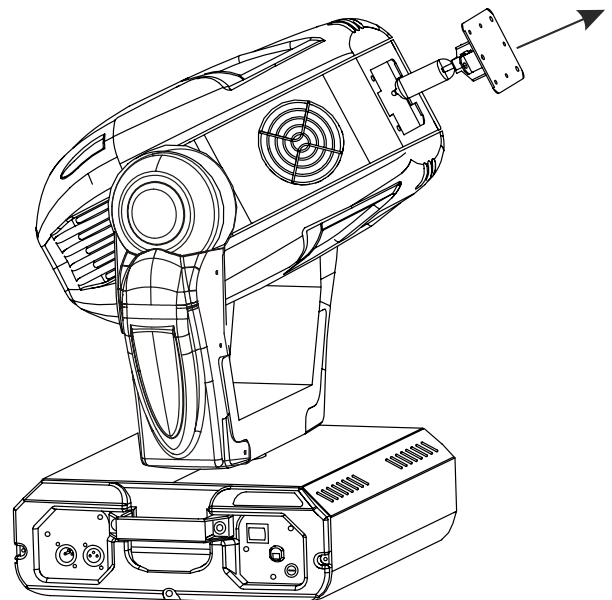
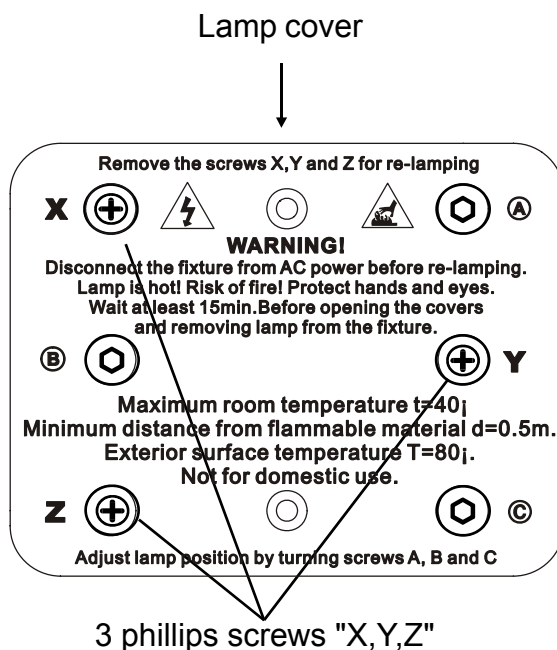

Do not operate this fixture with opened housing-cover!

5. Insert new lamp into socket. Ensure lamp is properly seated.
6. Carefully replace Lamp Cover and lamp. Ensure that lamp wires are not pinched or in contact with the lamp when the Lamp Cover is fully installed.
7. Replace the 3 fastening screws labeled X, Y and Z.

Lamp Alignment

Due to slight variations between lamps it may be necessary to perform fine adjustments to remove excessively dark or bright spots in the output field. The lamp holder is aligned at the factory, large adjustments to the alignment will not be necessary. Excessively bright spots can damage optical components.

1. Apply power to the fixture.
2. Using a controller, strike the lamp with shutter and dimmer to 100% and project an open white beam on a flat neutral colored surface.
3. Center the bright spot of the beam using the Adjustment Screws A, B and C.
4. After centering the bright spot of the beam, turn each Adjustment screw $\frac{1}{4}$ turn either all clock wise or all counter clock wise until the projected beam is as evenly bright as possible.



3 adjustment screws "A,B,C"

Mounting

Always consult a qualified professional when rigging. This fixture may be placed on any flat surface or truss that is capable of safely supporting the weight. When selecting a mounting position, take into consideration access for routine maintenance. This fixture may be mounted in any position provided there is adequate room for movement and ventilation. Mount the fixture securely using two mounting clamps and a safety cable. An Eye Bolt is provided for safety attachment. Safety cables must always be attached to the fixture. Do not use handles as secondary mounting points. Do not mount in a place where the fixture will be exposed to rain, high humidity, extreme temperature changes or restricted ventilation. Do not obstruct the vents or fans. Keep fixture a minimum of 3.3ft (1m) from flammable materials.

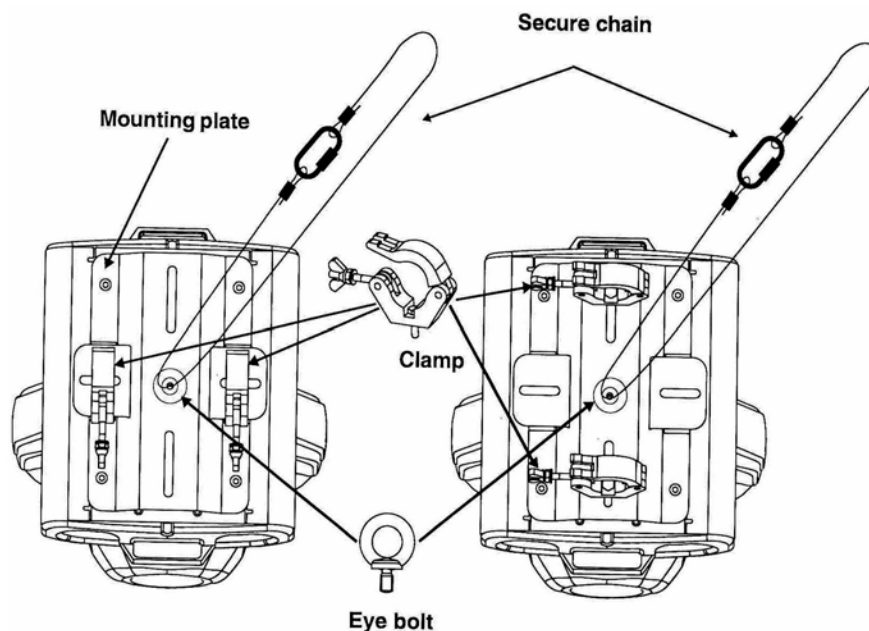

Data Link DMX-512

For data, this fixture uses 3 pin XLR (Cannon) type connectors and shielded twisted pair cable approved for EIA-422/EIA485 use. Fixtures are connected in Daisy Chain topography with only one data source and no branching is allowed. Systems using 5 pin DMX interfaces can be accommodated by purchasing 3-to-5 pin adapters or building adapter cables.

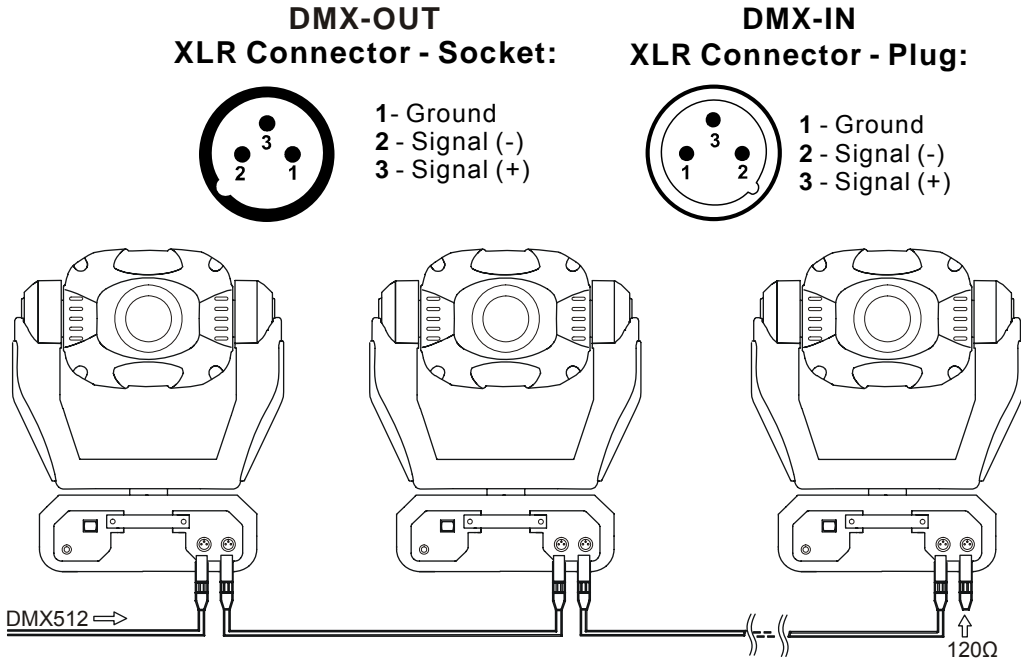

Data Terminator

A Data Terminator can be connected to the DATA OUT connection of the last fixture to reduce the effects of noise in the signal; it is not required for all installations. To make a Data Terminator, connect a 120-ohm ¼ watt resistor across pin 2, Data Negative (S-) and pin 3, Data positive (S+). A qualified technician can determine if a Data Terminator is needed.

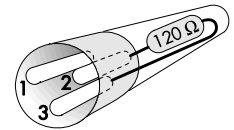

Adapter 5-to-3 pin

Numbers designating each pin can be found on connectors. Converting between the two XLR types is done in a pin-to-pin fashion. Connect the shields to pin 1, then connect pin 2 to pin 2 and pin 3 to pin 3. This is true for converting either 5 to 3 pin or 3 to 5 pin regardless of either connector's gender. Pins 4 and 5 are not used on the 5 pin XLR connectors.

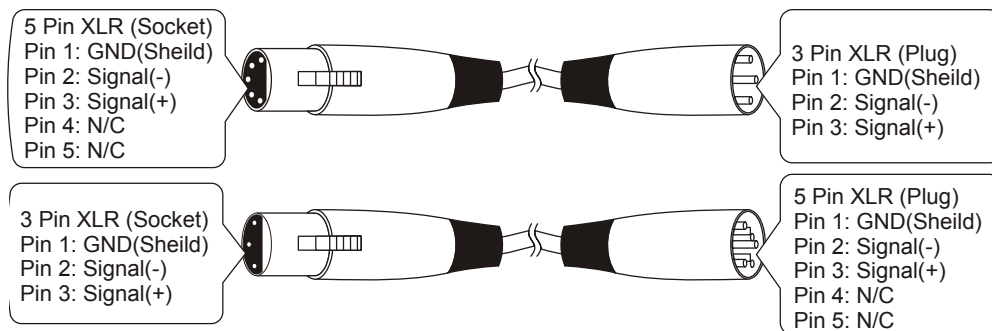

Control Panel Menu

Use the fixture's Control Panel to access the Control Menu. The MODE Key moves between options, UP/DOWN selects the Action of the option and ENTER confirms the selection. Settings are stored and recalled on subsequent power cycles.

<i>Mode</i>	<i>Function</i>	<i>Action</i>
<i>PAN</i>	Pan movement direction Invert	NO = Not Inverted YES = Inverted
<i>TILT</i>	Tilt movement direction Invert	NO = Not Inverted YES = Inverted
<i>Addr</i>	DMX Start Address	Selectable 1 to 512
<i>RESET</i>	Fixture Reset	NO = Default YES = Initiate Reset
<i>COLI</i>	Color Wheel Movement Mode	NO = Stepped Change YES = Linear Change
<i>run</i>	Operating Mode	OFF = DMX-512 mode PFB = Automatic Demo
<i>LAMP</i>	Lamp ON/OFF	ON = Not Inverted OFF = Inverted

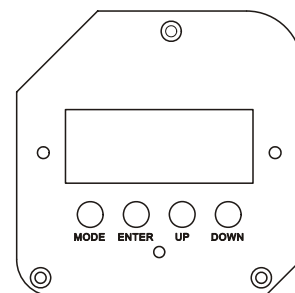

Start Address

The Start Address of a fixture is set using the “Addr” mode in the Control Panel Menu. Consult the manual of the system’s DMX512 controller to select a desirable addressing scheme before addressing fixtures. Each fixture connected to the DMX-512 data link requires a Start Address to indicate the first DMX channel containing data designated for that fixture, see DMX-512 Background. Valid Start Addresses range from 1 to 512. Fixtures requiring more than one channel for control will read subsequent channels up to the total number of channels required. A fixture requiring five (5) channels of DMX, set to a Start Address of eleven (11), would read data from channels: 11 and 12, 13, 14, 15. The next logical Start Address would be channel 16. Because all fixtures see the same data, fixtures may be set to any address without concern to order in the DMX-512 chain or physical location. Choose a Start Address so the channels used do not overlap with other fixtures. In some cases, it may be desirable to set two or more same type fixtures to the same Start Address. In this case, the fixtures will be slaved together and respond to the same data.

Example Select Start Addresses for 4 fixtures each requiring 16 channels of DMX.

Since these are the first fixtures added to the system, the first unit will be set to Start Address=1. This fixture occupies DMX channels 1 thru 16. The next DMX channel available for a Start Address is found by adding the previous fixture’s Start Address to its channel requirement: $1+16=17$. DMX channel 17 is the next available Start Address. In this example, to maximize channel usage no empty channels are left between fixtures so the second Start Address is set to DMX channel 17. The second fixture occupies DMX channels 17 thru 32. Repeat the process for the remaining two fixtures: $17+16=33$ and $33+16=49$. Therefore, the four 16 channel fixtures have Start Addresses of 1, 17, 33 and 49. Repeat the technique once more for the next free channel in the system, $49+16=65$. Channels 65 thru 512 are available for expansion of the system.

DMX-512 Channels

The Tracker 575 Wash requires 16 channels of DMX.

Channel	Function
1	Pan Coarse Movement
2	Pan Fine Movement
3	Tilt Coarse Movement
4	Tilt Fine Movement
5	Movement Speed Pan/Tilt
6	Control Reset/Lamp
7	Fixed Color Wheel
8	Cyan Mix
9	Magenta Mix
10	Yellow Mix
11	CMY Mix Speed
12	Color Presets CMY
13	Effects
14	Zoom
15	Shutter
16	Dimmer

CH 1-4 : Pan / Tilt Movement

The Pan and Tilt motors use a position feedback system. If the position of either is disturbed, the fixture will correct automatically. The Pan and Tilt Menu Modes can be used to alter the default direction of movement. Movement speed is either automatically determined by the fixture or manually set using Channel 5 Pan/Tilt Movement Speed. Pan range is 530° of movement. Tilt range is 280° of movement.

CH 1 – Pan Coarse Movement (530°)	
CH 2 – Pan Fine Movement	
CH 3 – Tilt Coarse Movement (280°)	
CH 4 – Tilt Fine Movement	
DMX Value	Function
0 – 255	Movement - Minimum to Maximum

CH 5 : Movement Speed Pan/Tilt

When set to zero (0) the fixture automatically determines the Pan/Tilt speed. Other values are used to set the movement speed manually.

CH 5 – Movement Speed Pan/Tilt	
DMX Value	Function
0	Auto Speed
1-255	Fixed Speed - Fast to Slow

CH 6 : Control Reset/Lamp

Fixture reset and Lamp On/Off control is accessed from a single channel. The “No Function” values provide buffer zones between functions and are not values to which the channel should be set. In the case of noisy faders or unintentional movement, the buffers will prevent slight variations in value to toggle Lamp states or start a fixture Reset.

CH 6 – Control Reset/Lamp	
<i>DMX Value</i>	<i>Function</i>
0-127	No Function
128-139	RESET then Lamp ON (3 second delay)
140-229	No Function
230-239	Lamp OFF (3 second delay)
240-255	No Function

CH 7 : Fixed Color Wheel

The Fixed Color Wheel holds 4 solid colors, 2 color correctors (CTO and CTB) and a UV effect filter. These color filters can be used in conjunction with the CMY color mixing to create many color combinations.

CH 7 – Fixed Color Wheel	
<i>DMX Value</i>	<i>Function</i>
0-24	Open
25-49	Red
50-74	Blue
75-99	Green
100-124	Orange
125-149	CTO Color Temperature Shift Down (Orange)
150-174	CTB Color Temperature Shift Up (Blue)
175-199	UV Effect
200-255	Color Rainbow effect Slow to Fast

CH 8 : Cyan Mix

Controls the saturation of the Cyan in the CMY color mixing system. This can be used in conjunction with the other CMY channels and the Fixed Color Wheel to create many color combinations.

CH 8 – Cyan Mix	
<i>DMX Value</i>	<i>Function</i>
0-255	Cyan Saturation - Least to Most

CH 9 : Magenta Mix

Controls the saturation of the Magenta in the CMY color mixing system. This can be used in conjunction with the other CMY channels and the Fixed Color Wheel to create many color combinations.

CH 9 – Magenta Mix	
<i>DMX Value</i>	<i>Function</i>
0-255	Magenta Saturation - Least to Most

CH 10 : Yellow Mix

Controls the saturation of the Yellow in the CMY color mixing system. This can be used in conjunction with the other CMY channels and the Fixed Color Wheel to create many color combinations.

CH 10 – Yellow Mix	
<i>DMX Value</i>	<i>Function</i>
0-255	Yellow Saturation - Least to Most

CH 11 : CMY Mix Speed

Controls the speed of all three CMY flags in the color mixing system.

CH 11 – CMY Mix Speed	
<i>DMX Value</i>	<i>Function</i>
0-255	Color Mix Speed - Fast to Slow

CH 12 : Color Presets CMY

Selects one of 18 preset mixes of the Cyan, Magenta and Yellow. This channel will override the CMY channels 8, 9 and 10.

CH 12 – Color Preset CMY	
DMX Value	Function
0-7	None (CMY under independent control)
8-13	Open (CMY channels 8, 9 & 10 values set to “0”)
14-27	Color Preset 1
28-41	Color Preset 2
42-55	Color Preset 3
56-69	Color Preset 4
70-83	Color Preset 5
84-97	Color Preset 6
98-111	Color Preset 7
112-125	Color Preset 8
126-139	Color Preset 9
140-153	Color Preset 10
154-167	Color Preset 11
168-181	Color Preset 12
182-195	Color Preset 13
196-209	Color Preset 14
210-223	Color Preset 15
224-237	Color Preset 16
238-251	Color Preset 17
252-255	Color Preset 18

CH 13 : Effects

The standard projection from this fixture is a round soft edge beam. Modification of the beam can be done with either a Frost Effect, creating a very wide diffused edge or with the Beam Shape Effect (Lenticular), creating an oblong beam that can be rotationally adjusted 180° on axis.

CH 13 – Effects	
DMX Value	Function
0-49	Open
50-99	Frost
100-255	Beam Shape - 0° to 180°

CH 14 : Zoom

Beam angle can be varied continuously from 7° to 28°.

CH 14 – Zoom	
DMX Value	Function
0-255	Beam Angle - Wide 28° to Narrow 7°

CH 15 : Shutter

The Shutter functions in three modes. Standard Strobe Effect where the shutter Opens/Closes at a fixed rate. Pulse Strobe Effect where the Open and Close speeds are different. Random Strobe Effect runs the shutter at irregular intervals.

CH 15 – Shutter	
<i>DMX Value</i>	<i>Function</i>
0-31	Closed (Black Out)
32-63	Open
64-95	Strobe Effect - Slow to Fast
96-127	Open
128-131	Pause
132-159	Pulse Strobe Effect - Slow to Fast
160-191	Open
192-223	Random Strobe Effect
224-255	Open

CH 16 : Dimmer

The dimmer is used to vary the intensity of the beam from full open to dark.

CH 16 – Dimmer	
<i>DMX Value</i>	<i>Function</i>
0-255	Intensity - Dark to Full Open

Photometric Charts

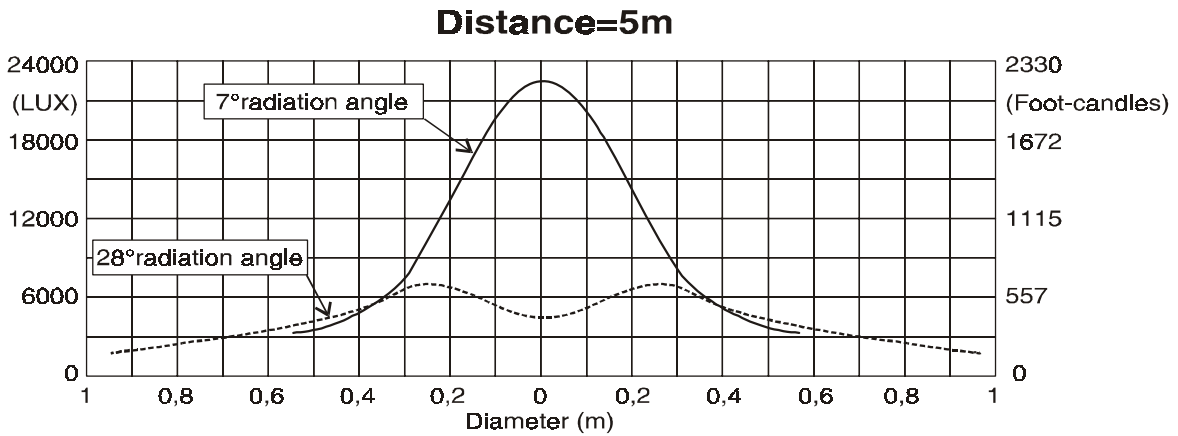
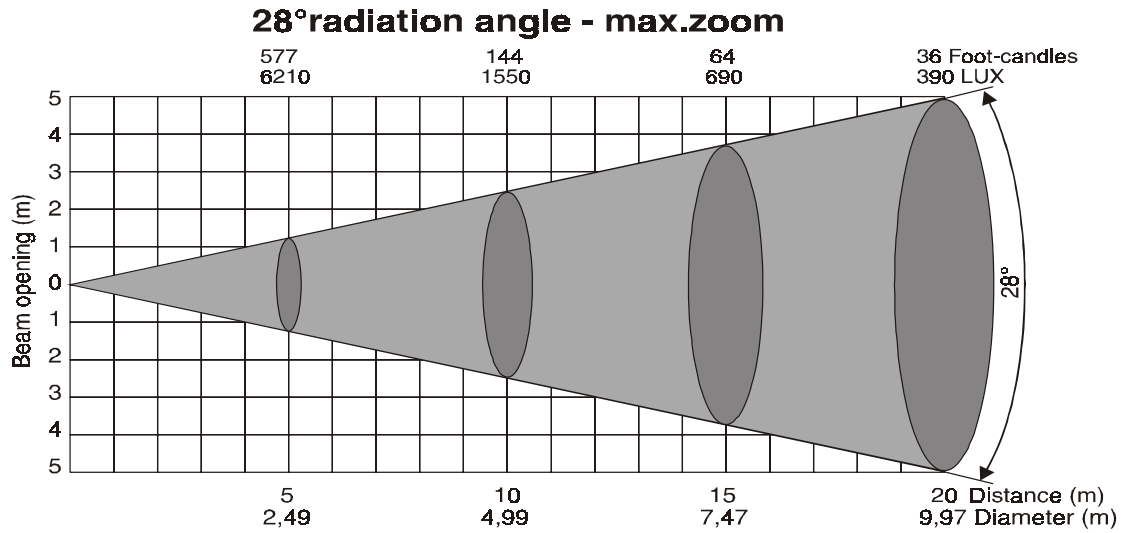
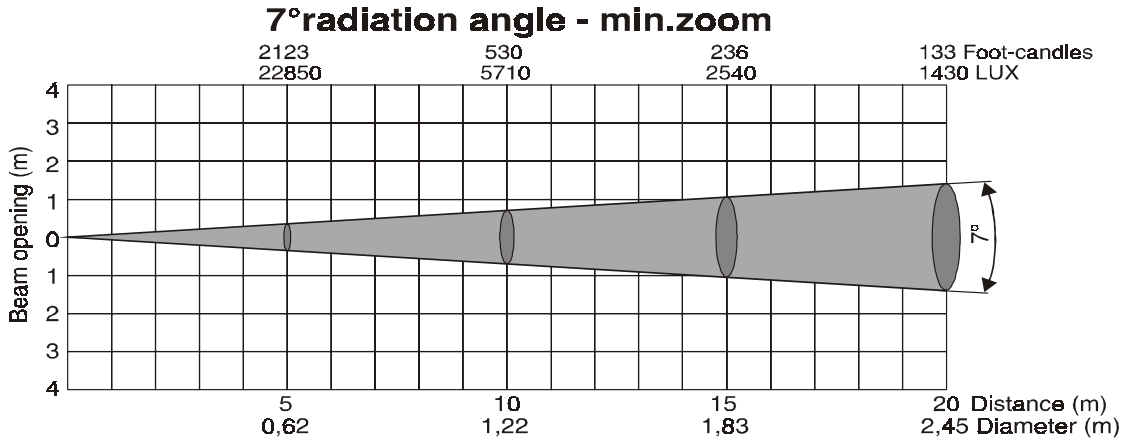

DMX-512 Background

DMX-512 is a digital data transmission standard developed by the United States Institute for Theater Technology (USITT). It is designed to enable control of lighting equipment, originally dimmers. DMX deals solely with the formatting of data for transmission and does not dictate how the data is created or used.

Under DMX, signals are transmitted in much the same way a computer modem transmits data. The Data, divided in to channels, is "Framed" using a start bit, high (1), eight data bits and finally, two stop bits, both high (1). DMX uses no parity to check the integrity of the signal. Instead, DMX relies on the ultra low probability of an error occurring in the same place when the data is resent. The rate at which data is sent is fixed at 250k bps, almost four and a half times faster that a 56k modem. This speed allows all data on a DMX chain to be updated more than 44 times every second.

The transmitted data follows a specific format. DMX allows for 512 channels each with eight data bits, giving each channel the possibility of 256 values. When a data "Packet" is sent, all channels are transmitted one after another. Even if the data on a specific channel has not been changed, it must be sent. In a packet, a "start code" of all zeros is sent before the data to identify the signal as a Standard DMX transmission. This start code is transparent to the user and is handled by the controller.

The physical signals are transmitted using a twisted pair of wires and a common shield, a configuration called Balanced. The controller and all receiving equipment are connected using a "Daisy Chain" connection. The signal is jumped from the controller to a piece of DMX equipment. From there, the signal is jumped to the next piece of equipment and so on until the last piece of equipment is connected. No branches are allowed and the signal does not come back to the controller. The final piece of equipment will have only one cable connection. As a result, all equipment connected to the chain will see exactly the same signal whether it is first or last. When connecting equipment, no particular attention needs to be paid to the order in which the equipment is connected. Depending on the conditions and equipment, a line terminator may be required. If there is any question, in most circumstances the addition of a terminator will not degrade the signal. To make a terminator, add a 120-ohm resistor between the Signal Data Negative and Signal Data Positive pins of a connector in the last piece of equipment in the chain.

The DMX Standard calls for connections between DMX compatible equipment to be made using 5 pin XLR connectors. However, it is common to see fixtures with 3 pin XLR connectors as these types of balanced or "Lo-Z" cables are common in the audio industry. In either case, pin numbers are the same and carry the same signals.

Pin 1	-	Signal Common (Shield)
Pin 2	-	Signal Data Negative
Pin 3	-	Signal Data Positive
Pin 4	-	(not used)
Pin 5	-	(not used)

Maintenance



Make sure fixture is cool and disconnected from power mains before any service.
Do not touch the lamp glass with bare fingers. Wear eye protection when handling lamp

Weekly operating hours and environmental conditions will establish how often the fixtures need cleaning. Fixtures should be cleaned and inspected at least once a month to maintain optimum performance. Accumulation of dust and fog residue increases heat build up, can lead to malfunctions, overheating and reduction in maximum light output. This condition may cause undue stress on electronics, mechanical elements, reduce lamp life, fixture life and over all performance. Before conducting any maintenance, disconnect fixture from power mains.

- 1) Disconnect fixture from power mains.
- 2) Use a vacuum with a soft brush to remove dust collected on external vents and internal components. If using an air compressor, use low pressures and extreme care to prevent damaging any internal parts or effects.
- 3) Vacuum dust buildup from fan intakes and check that all fans function correctly.
- 4) Clean all optical elements when the fixture is cold. Use a soft lint free cotton cloth or tissue and either Isopropyl or Denatured Alcohol. Any cleaner approved for coated eyeglass lenses will also work.
- 5) Inspect clamps and safety cables to ensure fixture is secure and safe.

Troubleshooting

Symptom	Possible Cause / Solution
No Power	Check for power on mains
	Check power switch
	Check main fuse and fuse holder
No response to DMX	Check data cables
	Check Start Address
	Check that fixture isn't in the Demo mode
Incorrectly responds to DMX (Diagnostic technique for DMX issues: Set suspect fixture's Start Address the same as a correctly functioning fixture. If both units then function correctly, issue is programming)	Check Start Address
	Check for overlapping addresses
	Check fixture set up (Pan/Tilt Invert...)
	Check Data cables (faults and proper wiring)
No Lamp Power	Bad or end of life lamp
	Check DMX value for Control/Reset Lamp Channel
	Inspect fixture light path and verify no effects are blocking beam
	Remove from DMX and check to see if lamp can be struck from Control Panel
	Over temperature error – Turn Lamp off and allow fixture to cool then attempt to restrike the lamp. If this is the case, check all fans.
Erratic operation	See "Incorrectly responds to DMX"
	Check for properly wired DMX cables
	Check for broken wires inside unit
	Check for damaged Data transceiver IC.
An effect wheel doesn't go to correct position	Check sensor and magnet
	Check belts (if applicable)
	Check motor with no power, should be able to move easily.

Wiring Diagram

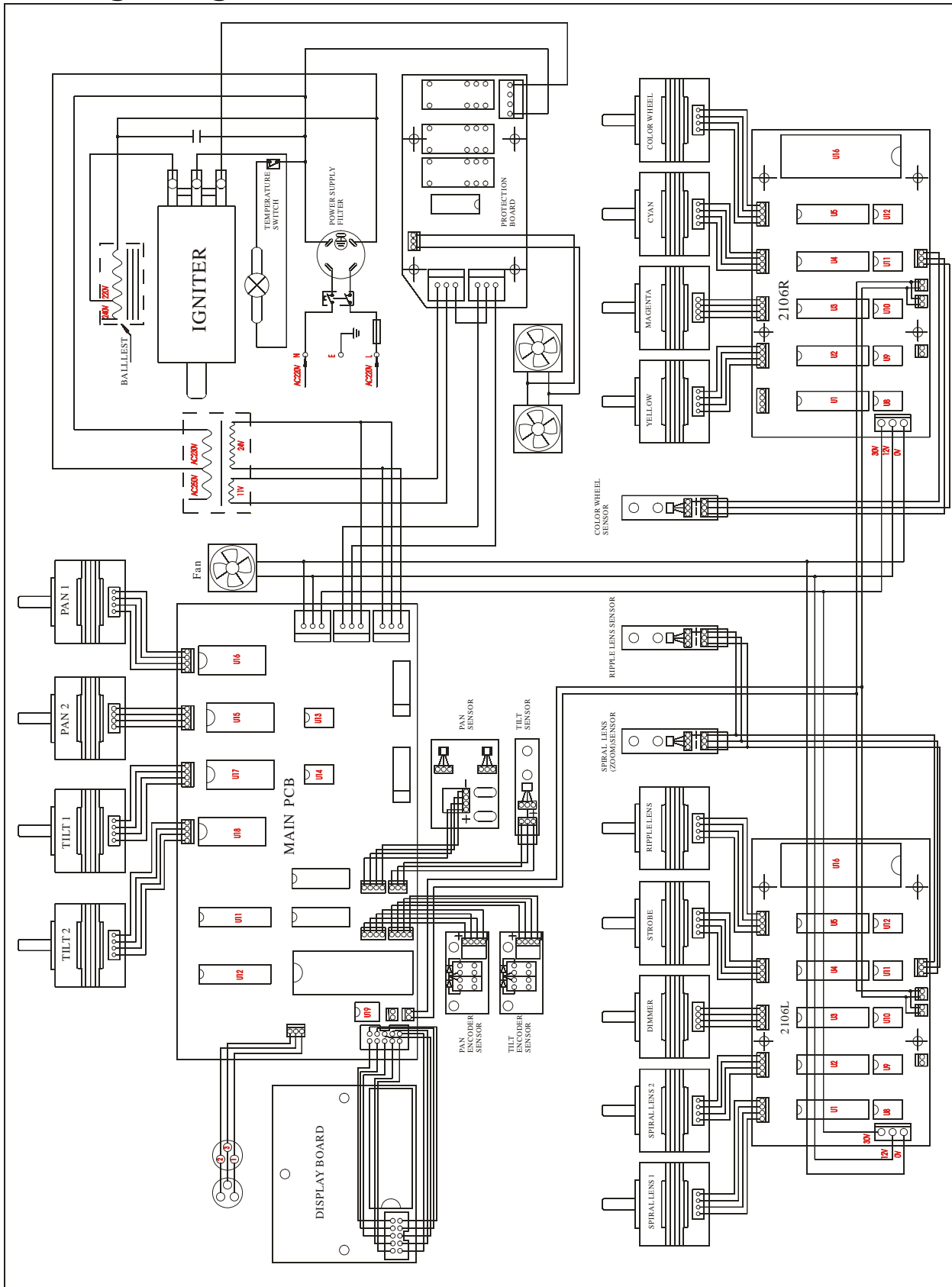

Accessory Items

Order Code	Description
LCSR575/2SE-G	Replacement Lamp GE CSR575/2, 575w, 1000 Hours, 7200K
LMSR575/2-P	Replacement Lamp Phillips MSR575/2, 575w, 1000 Hours, 7200K
CLAMP-MEGA/B	Clamp-Mega Black - Heavy Duty
CLAMP-CBHALF	Coupler Half Cheeseborough
SAFETYCABLE1	Safety Cable Silver 30"
SAFETYCABLE2	Safety Cable Black 30"
SAFETYCABLE3	Safety Cable Black 18"
SAFETYCABLE4	Safety Cable Silver 18"
CA-XLR3/1	Pre-made 1' 3-pin XLR Cable
CA-XLR3/5	Pre-made 5' 3-pin XLR Cable
CA-XLR3/10	Pre-made 10' 3-pin XLR Cable
CA-XLR3/20	Pre-made 20' 3-pin XLR Cable
CA-XLR3/50	Pre-made 50' 3-pin XLR Cable
CA-XLR3/100	Pre-made 100' 3-pin XLR Cable
CO-XLR3M	XLR Connector 3-pin Male
CO-XLR3F	XLR Connector 3-pin Female
CO-XLR5M	XLR Connector 5-pin Male
CO-XLR5F	XLR Connector 5-pin Female
CO-XLRTERM3	XLR 3 Pin Data Terminator
CO-XLR3MTO5F	XLR 3 Pin Male to 5 Pin Female Adapter
CO-XLR5MTO3F	XLR 5 Pin Male to 3 Pin Female Adapter